

2005 SHM 1450SR-HS Sheeter

- Complete Sheeter line
- 57 inch (1450 mm) SHM Single Knife Sheeter
- Shaftless dual unwind stand model PBF 201/D. 73" (1850mm) roll diameter
- Tidland Class II slitting unit, 3 slitters, 2 pocket
- One Motorized Edge/Roll Decurler and One Dancer Tensioning system and One Pemco 2 bar decurler
- 1000 fpm (300 m/min) maximum mechanical speed
- Piler with Metal Skid Plate, 2 pocket capability, 47 inch (1200 mm) Pile height, 4400lb (2000 kg) Pile weight
- Knife Outfeed Tape Belt Section, Overlap Vacuum, Shingling Section, and Accumulation Conveyor
- Sheet Width 57 inch (1450 mm) inch maximum
- Sheet Length 59 inch (1500 mm) maximum
- Wire and Wireway provided As-Is. Dependent upon removal
- Prints and Manuals provided
- Sold As-Is, Where-Is. Pre-Owned warranty does not apply
- Customer visit and inspection required

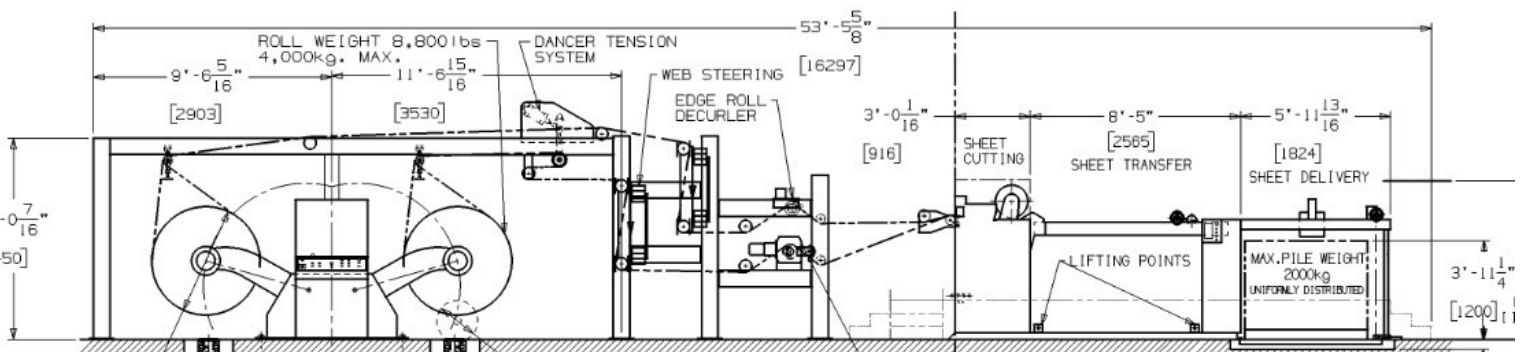

WillPemcoBielomatik, Inc.

3300 Crocker Avenue
Sheboygan, WI 53081

t. +1 (920) 458 2500
bwpapersystems.com